

Model	Tower System Tons	Dimensions Inches			Connections Inches			Pump HP	FLA @ 460/3/60	Shipping Weight Lbs.	Operating Weight Lbs.
		L	W	H	Inlet	Outlet	Drain				
PS20F	20 - 400	66	30	54	2	2	2	1	2.4	350	445
PS24F	400 - 600	69	30	54	2	2	2	2	3.0	470	600
PS30F	600 - 1,000	72	35	54	2	2	2	3	4.5	740	995
PS36F	1,000 - 1,400	77	48	65	3	3	3	3	4.5	1,550	2,045
PS42F	1,400 - 1,900	77	48	65	3	3	3	5	7.5	2,265	2,970
PS48F	1,900 - 2,500	83	48	66	3	3	3	5	7.5	3,875	4,995

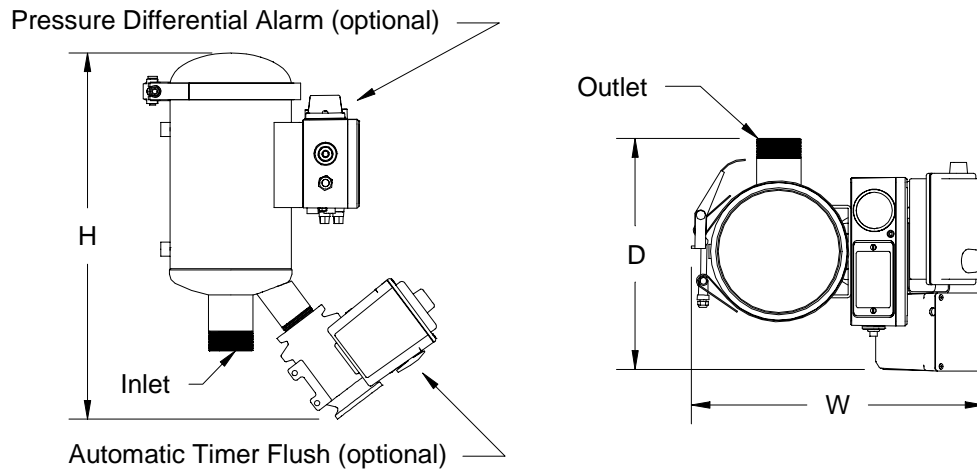

Model	Dimensions Inches			Connection Size Inches		Flush Port Inches	Weight Lbs.
	H	W	D	Inlet	Outlet		
SF100	15 7/8	15 3/4	12 1/4	2	2	1 1/2	13

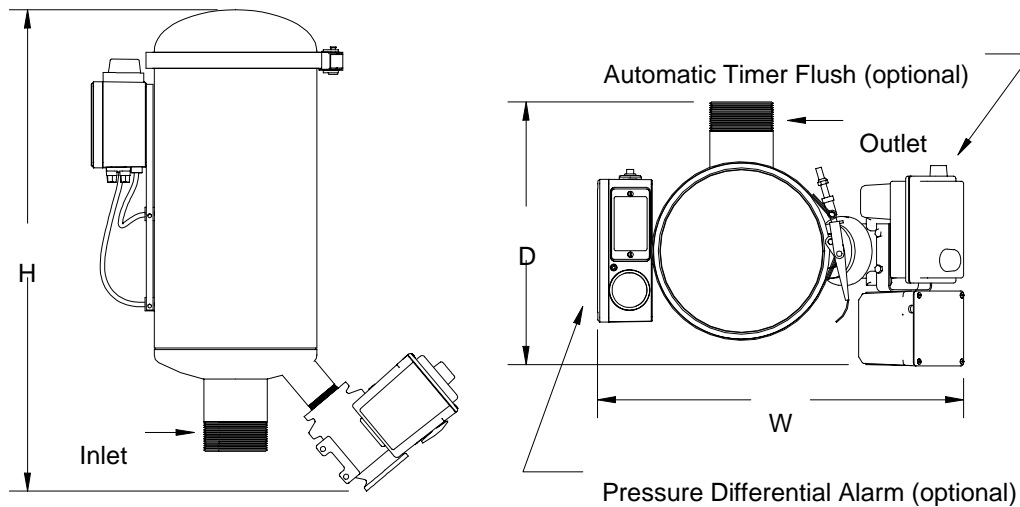

Model	Dimensions Inches			Connection Size Inches		Flush Port Inches	Weight Lbs.
	H	W	D	Inlet	Outlet		
SF200	24 1/2	20 1/4	14 1/2	3	3	1 1/2	27

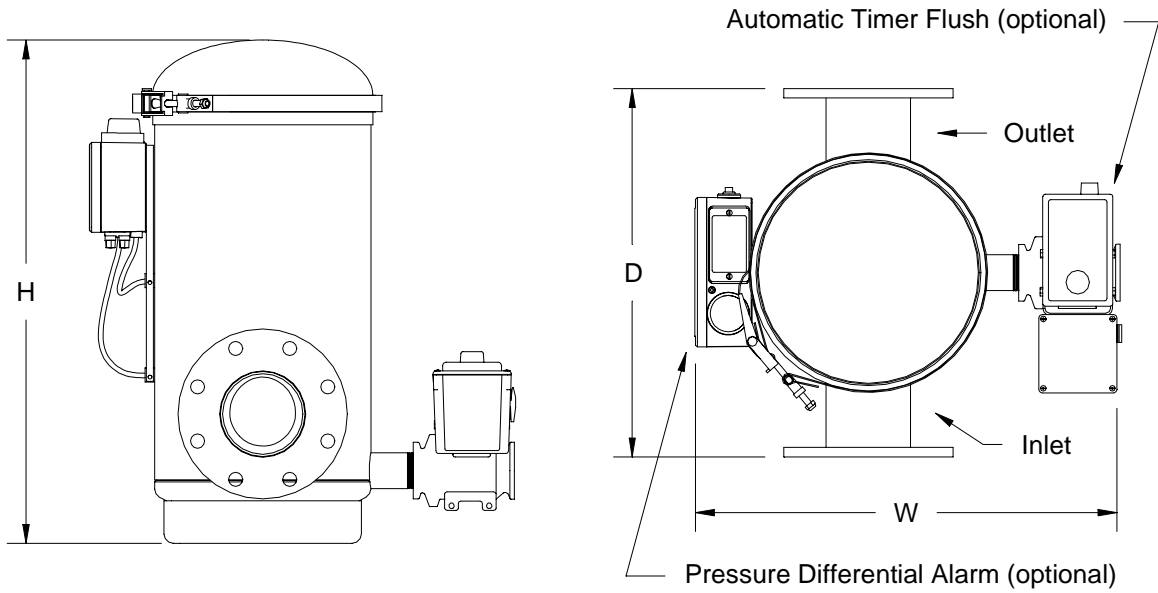

Model	Dimensions Inches			Connection Size Inches		Flush Port Inches	Weight Lbs.
	H	W	D	Inlet	Outlet		
SF350	25 1/2	22 3/4	19 1/2	4	4	1 1/2	60

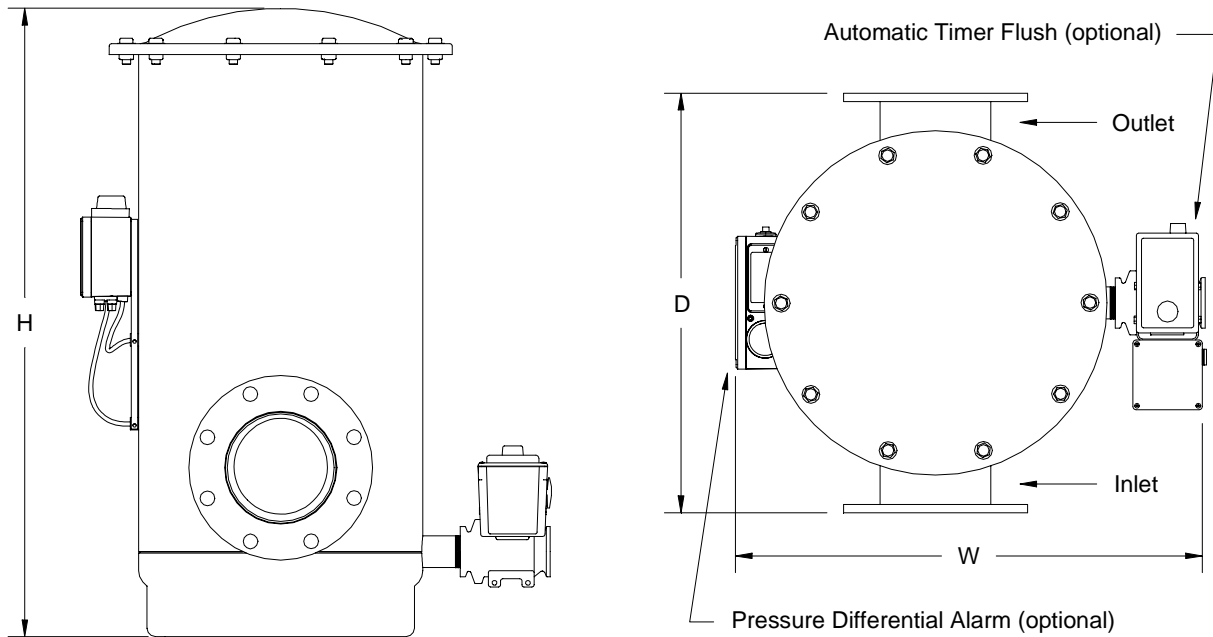

Model	Dimensions Inches			Connection Size Inches		Flush Port Inches	Weight Lbs.
	H	W	D	Inlet	Outlet		
SF750	37 1/2	28 1/4	25	6	6	1 1/2	125
SF1300	48 1/4	34 1/4	31 1/2	8	8	1 1/2	230
SF2000	59 1/2	41 1/4	39 3/4	10	10	1 1/2	400



7720 North Lehigh Avenue
 Niles, Illinois 60714-3491
 Tel: (847) 966-2260
 Toll Free: (888) 828-7387
 Fax: (847) 966-9358

Email: info@thermalcare.com
 Website: www.thermalcare.com

Manufacturer reserves the right to change specifications or design without notice or obligation. Thermal Care is a registered trademark of MFRI, Inc.

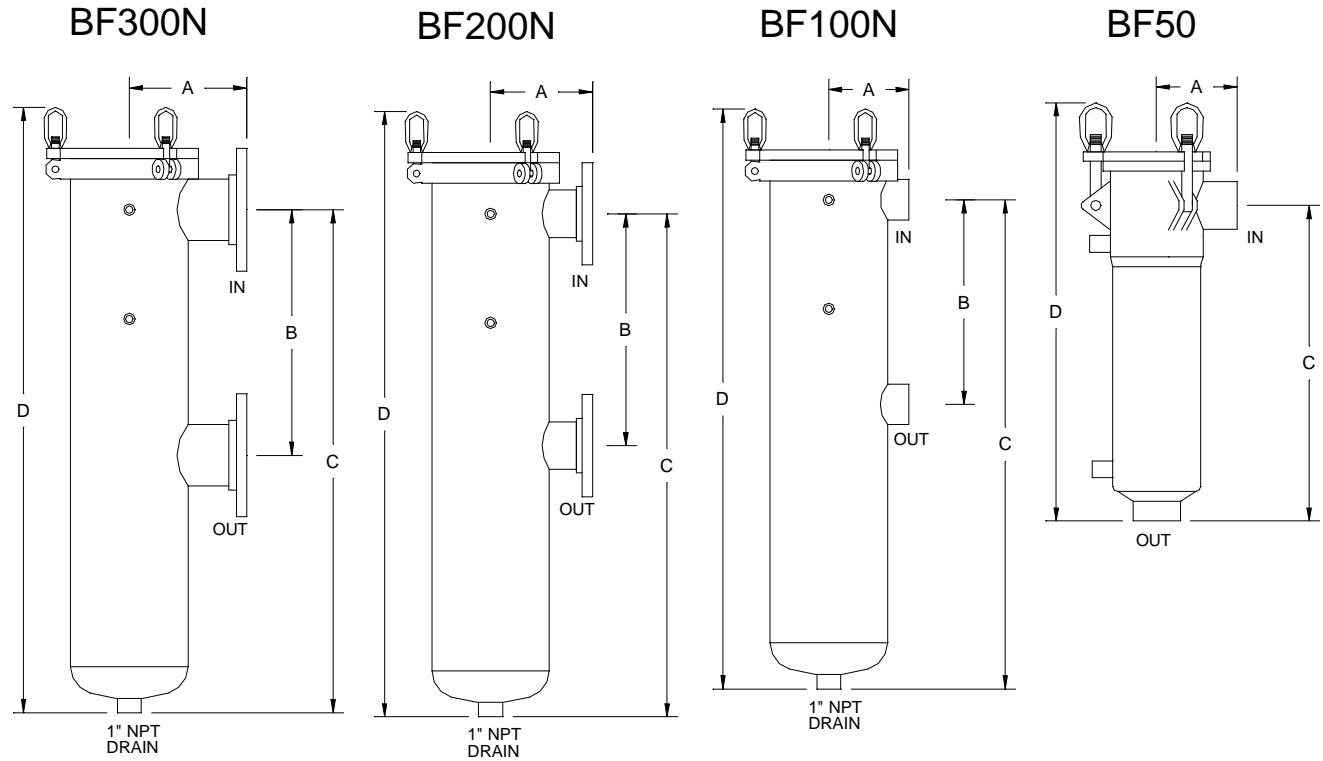

Model Number	Standard Filter Mesh	Dimensions (Inches)				Inlet (Inches)	Outlet (Inches)	Weight (Pounds)
		A	B	C	D			
BF50	60	4 1/8	-	16 1/8	21 3/8	1 1/2	1 1/2	25
BF100N	60	5 7/8	4 7/8	36	43 3/8	2	2	140
BF200N	60	7 1/2	6 5/8	36 7/8	44 3/8	3	3	150
BF300N	60	8 3/8	8 3/8	36 7/8	44 3/8	4	4	160

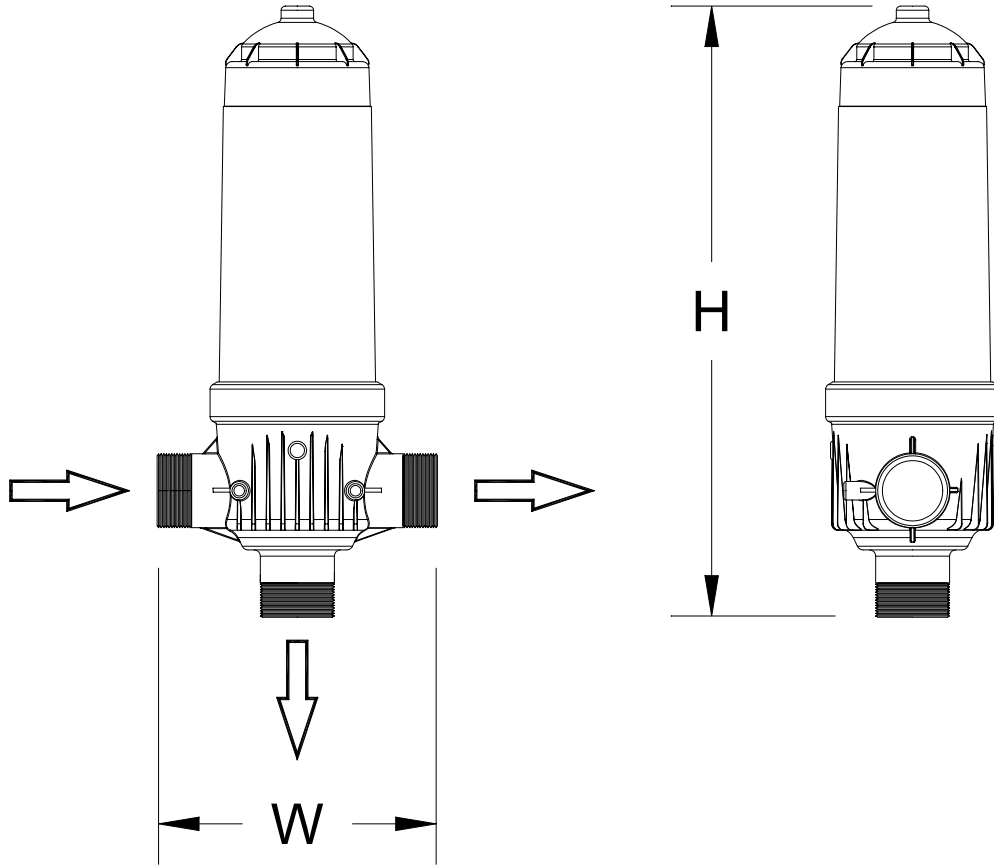

Model	Filter Mesh	Dimensions Inches		Connection Size Inches			Weight Lbs.
		H	W	Inlet	Outlet	Flush Port	
TD100	80	23 13/16	12 3/16	2	2	3/4	17
TD200	80	29	13 1/4	3	3	3/4	20