

General

The TC Series of central chillers are quality run-tested in our ISO 9001:2000 certified facility using refrigerant and water and ship with a full charge of refrigerant. Units provided with a remote condenser ship with a nitrogen holding charge. A heavy gauge galvanized steel bolted frame supports all of the components of every unit.

Centrifugal Compressor(s)

- Variable speed direct drive compressor motor
- Frictionless magnetic bearings
- Electronic bearing sensors
- R134a HFC refrigerant
- Totally oil-free operation
- Impeller keyed direct on motor rotor
- Computer controlled liquid refrigerant cooling of electronic, mechanical and electro mechanical components
- Inlet guide vane assembly
- Soft start motor control
- Variable speed direct drive motor control
- High voltage DC power rectifier
- High capacity storage/filter capacitors

Evaporator(s)

- Brazed plate type with stainless steel plates and copper brazing
- Refrigerant side working pressure of 450 PSIG
- Water side working pressure of 435 PSIG
- Electronic thermal expansion valve
- Safety flow switch
- Fully insulated with 3/8 inch Armaflex insulation
- Evaporator supply and return water manifolds with isolation valves and 3/8 inch Armaflex insulation (dual circuit units)

Condenser(s)

- Shell and tube type with steel shell and copper tubes
- Removable head for cleaning
- Cleanable tubes
- Refrigerant side working pressure of 400 PSIG
- Water side working pressure of 150 PSIG
- Electronic condenser water regulating valve

Refrigerant Circuit(s)

- Two independent refrigeration circuits (dual circuit units)
- Liquid line refrigerant dryers with removable core
- Combination moisture indicator/sight glass
- Electronic expansion valve
- Charging valve
- Suction line insulation with 3/8 inch Armaflex insulation
- High side relief valve (350 PSIG for water cooled units, 450 PSIG for air cooled units)

Control Panel

- NEMA-4 control panel
- 24 VDC control circuit power
- Compressor contactor and overload
- Branch circuit fusing
- Control panel mounted to chiller frame and wired to compressor motor and sensors
- 2-line, 20 character per line operator control system user interface
- Chiller on/off switch

PLC Controller

- Compressor monitoring and control through Modbus communications
- **Alarm Displays:** Inverter temperature, discharge temperature, suction pressure, discharge pressure, 3-phase current trip, shaft cavity temperature, high chilled water out temperature, total compression ratio fault, bearing faults, motor faults, SCR temperature fault, and chiller interlock
- **General Display Information:** Load profile broken down into hours/minutes/seconds of operation in 10 load segments (ie. 0% to 10%, 10% to 20%, etc.), inlet guide vane percent open, suction pressure, discharge pressure, suction temperature, discharge pressure, SCR temperature, cavity temperature, liquid refrigerant temperature, chilled water inlet temperature, chilled water outlet temperature, condenser water inlet temperature, compressor interlock status, percent demand, chiller on/off status, set point temperature, proportional gain, integral gain, estimated minimum speed, maximum speed, units of measure (Imperial or Metric), percentage suction pressure limit, suction pressure alarm delay period in seconds, alarm delay countdown
- **Electronic Expansion Valve Display Information:** superheat, percentage open, start position percentage, delay time to hold start position, superheat set point, valve control speed value
- **Electronic Condenser Water Regulating Valve Display Information:** Percentage open, start position (percentage open), and time delay valve to hold start position
- **Bearing Display Information:** Shaft position, axial unbalance, front unbalance, rear unbalance, axial force amps, front X force amps, front Y force amps, rear X force amps, and rear Y force amps
- **Soft Start Display Information:** Actual demand power (kW), 3-phase VAC, 3-phase amps, and DC bus
- **Motor Display Information:** Actual RPM, desired RPM, motor amps, earth current, power (kW), and inverter temperature

Warranty

- One year parts and labor

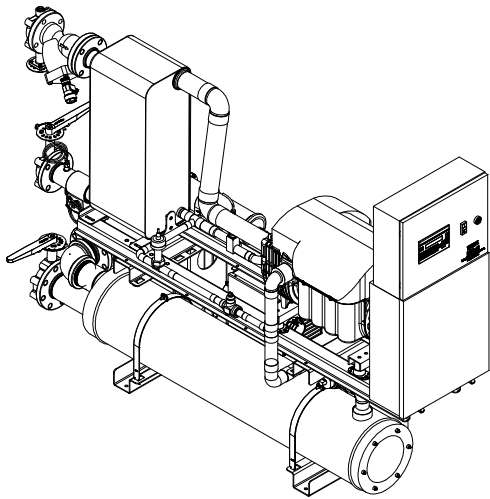

Single-Circuit Water Cooled Chillers

Standard Efficiency Models	TCW60	TCW70	TCW80	TCW90
Cooling capacity ¹ (tons)	60	70	80	90
Compressor (qty) tons each	(1) 60	(1) 70	(1) 80	(1) 90
Refrigerant type	R134a	R134a	R134a	R134a
Refrigerant charge (lbs)	70	70	90	90
Minimum load standard (tons)	12	14	16	18
Minimum load with optional hot gas bypass valve (tons)	3	3.5	4	4.5
Set point range (°F)	40 to 75	40 to 75	40 to 75	40 to 75
Unit MCA ² @ 460/3/60	115	133	151	168
Sound pressure at 1 meter (dBA)	72	72	72	72
Nominal process water flow rate (GPM)	143	167	191	215
Process water pressure drop (PSI)	8	8	8	8
Process water inlet and outlet flanges (in)	3	3	4	4
Nominal condenser flow rate (GPM)	180	210	240	270
Condenser water pressure drop (PSI)	4	4	4	5
Condenser inlet and outlet flanges (in)	4	4	4	4
Shipping weight (lbs)	1800	1900	2100	2400
Operating weight (lbs)	2000	2100	2300	2600
Length (in)	95	95	98	98
Width (in)	26	26	26	26
Height (in)	68	68	68	68
High Efficiency Models	TCW60HE	TCW70HE	TCW80HE	TCW90HE
Cooling capacity ¹ (tons)	60	70	80	90
Compressor (qty) tons each	(1) 60	(1) 70	(1) 80	(1) 90
Refrigerant type	R134a	R134a	R134a	R134a
Refrigerant charge (lbs)	85	85	110	110
Minimum load standard (tons)	12	14	16	18
Minimum load with optional hot gas bypass valve (tons)	3	3.5	4	4.5
Set point range (°F)	40 to 75	40 to 75	40 to 75	40 to 75
Unit MCA ² @ 460/3/60	115	133	151	168
Sound pressure at 1 meter (dBA)	72	72	72	72
Nominal process water flow rate (GPM)	143	167	191	215
Process water pressure drop (PSI)	8	8	8	8
Process water inlet and outlet flanges (in)	3	3	4	4
Nominal condenser flow rate (GPM)	180	210	240	270
Condenser water pressure drop (PSI)	4	4	4	5
Condenser inlet and outlet flanges (in)	4	4	4	4
Shipping weight (lbs)	1850	2000	2250	2650
Operating weight (lbs)	2050	2300	2450	2850
Length (in)	95	95	98	98
Width (in)	26	26	26	26
Height (in)	68	68	68	68

¹ Nominal cooling capacity with 50°F leaving fluid and 85°F entering condenser water.

² MCA (Minimum Circuit Ampacity) based on 125% of largest compressor RLA plus 100% of second compressor RLA per NEC 440-33.

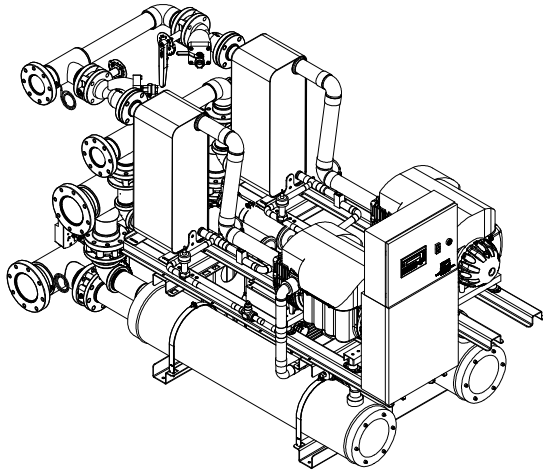

Dual-Circuit Water Cooled Chillers

Standard Efficiency Models	TCW120	TCW140	TCW160	TCW180
Cooling capacity ¹ (tons)	120	140	160	180
Compressor (qty) tons each	(2) 60	(2) 70	(2) 80	(2) 90
Refrigerant type	R134a	R134a	R134a	R134a
Refrigerant charge (lbs)	140	140	180	180
Minimum load standard (tons)	24	28	32	36
Minimum load with optional hot gas bypass valves (tons)	6	7	8	9
Set point range (°F)	40 to 75	40 to 75	40 to 75	40 to 75
Unit MCA ² @ 460/3/60	207	239	272	302
Sound pressure at 1 meter (dBA)	74	74	74	74
Nominal process water flow rate (GPM)	287	335	382	430
Process water pressure drop (PSI)	8	8	8	8
Process water inlet and outlet flanges (in)	4	4	6	6
Nominal condenser flow (GPM)	360	425	480	534
Condenser water pressure drop (PSI)	4	4	4	5
Individual condenser inlet and outlet flanges (in)	4	4	4	4
Condenser manifold option inlet & outlet flanges (in)	6	6	6	6
Shipping weight (lbs)	3700	3800	4100	4700
Operating weight (lbs)	4000	4200	4600	5200
Length (in)	109	109	111	111
Width (in)	51	51	53	53
Height (in)	68	68	68	68
High Efficiency Models	TCW120HE	TCW140HE	TCW160HE	TCW180HE
Cooling capacity ¹ (tons)	120	140	160	180
Compressor (qty) tons each	(2) 60	(2) 70	(2) 80	(2) 90
Refrigerant type	R134a	R134a	R134a	R134a
Refrigerant charge (lbs)	170	170	220	220
Minimum load standard (tons)	24	28	32	36
Minimum load with optional hot gas bypass valves (tons)	6	7	8	9
Set point range (°F)	40 to 75	40 to 75	40 to 75	40 to 75
Unit MCA ² @ 460/3/60	207	239	272	302
Sound pressure at 1 meter (dBA)	74	74	74	74
Nominal process water flow rate (GPM)	287	335	382	430
Process water pressure drop (PSI)	8	8	8	8
Process water inlet and out flanges (in)	4	4	6	6
Nominal condenser flow rate (GPM)	360	425	480	534
Condenser water pressure drop (PSI)	4	4	4	5
Individual condenser inlet and outlet flanges (in)	4	4	4	4
Condenser manifold option inlet & outlet flanges (in)	6	6	6	6
Shipping weight (lbs)	3750	4000	4450	5200
Operating weight (lbs)	4100	4600	4950	5700
Length (in)	109	109	111	111
Width (in)	51	51	53	53
Height (in)	68	68	68	68

¹ Nominal cooling capacity with 50°F set point and 85°F condenser water.

² MCA (Minimum Circuit Ampacity) based on 125% of largest compressor RLA plus 100% of second compressor RLA per NEC 440-33.



7720 North Lehigh Avenue
Niles, Illinois 60714-3491
Tel: (847) 966-2260
Toll Free: (888) 828-7387
Fax: (847) 966-9358

Email: [info @ thermalcare.com](mailto:info@thermalcare.com)
Website: www.thermalcare.com

*Manufacturer reserves the right to
change specifications or design
without notice or obligation.
Thermal Care is a registered
trademark of MFRI, Inc.*